

Mobile Systems Quik-Spec Specifications
Manual Mobile Aisle Series

3" — 1,000 LB. SERIES

For systems up to 1000 lbs. per linear ft.

TRACKS

1.0 System designed to utilize C, Low Pro, T or Anti-tip tracks based on wheel selection.

1.1 Shims are provided, as appropriate, for proper leveling to ensure smooth operation.

1.2 Tracks may be secured to the floor with rawl type anchors or double-sided tape.

1.3 All track sections are designed with a tongue and groove lap connection between each rail joint. This provides a superior connection and proper alignment for smooth carriage movement.

**RAISED FLOOR DECKING
(WHEN APPLICABLE)**

2.0 Decking to be constructed of 3/4" high density cabinet grade plywood. Flame retardant decking is an option.

2.1 Decking shall support a minimum of 250 lbs. per sq. ft.

2.2 Decking to be installed flush and tight to the track.

2.3 Decking to be installed in a manner that will prevent warping, deformation and movement during normal use and operation.

2.4 Decking may be finished with floor covering as specified by end user.

RAMPS

3.0 Beveled ramp grade shall be ADA compliant.

3.1 Ramps constructed of 3/4" plywood in 14", 18", or 24" width as determined by carriage length.

CARRIAGES

4.0 All carriages are of 3" high welded steel construction; carriage side members consist of 12 gauge welded steel and are capable of supporting 1000 lbs. per lineal carriage foot.

4.1 Carriage cross members are 12 gauge 1 1/2" x 3" welded "U" shaped steel channels.

4.2 Optional fixed carriages shall be of the same construction and height as movable carriages and shall be anchored to the floor for a complete, homogeneous system.

4.3 Carriage design allows shelving to be securely anchored to the top surface of all carriages.

WHEELS

5.0 All wheels to be a minimum of 3 1/4" in diameter, double flanged, precision ground, balanced and constructed from solid steel for smooth operation.

5.1 A minimum of four wheels is required per movable carriage.

END PANELS

6.0 All optional end panels are to be the full height and depth of the shelving ends.

6.1 Melamine or high pressure laminate covered end panels to be 3/4" in thickness.

6.2 Optional laminates are available upon customer request.

6.3 Shelving closed end panels may be used as finished product.

ATTACHMENT OF SHELVING

7.0 Carriage construction shall be designed to allow numerous shelving designs to be securely anchored to the carriages. Shelving shall be secured to the carriages with special tek screws provided.

QUALITY CONTROL

8.0 Systems are checked at the factory to ensure high quality and uninterrupted field installation.

INSTALLATION STANDARDS

9.0 All parts and fasteners are provided to ensure proper and safe installation.

9.1 All mobile systems are to be installed by trained technicians.

CLEAN UP & DOCUMENTATION

10.0 All debris and excess materials resulting from installation shall be removed and the construction area left in a broom clean condition.

10.1 Additional Operators Manuals are available upon request.

*DATE: OCTOBER 1, 2003
SPECIFICATIONS ARE SUBJECT TO CHANGE.*

Mobile Systems Quik-Spec Specifications
1000 lb. LP3 Mechanical Assist Carriage

TTRACK

1.0 Rail to be 1/2" wide x 3/4" high # 1018 cold rolled steel rail positioned in 6063T56 "T" aluminum extrusion. Rail to be machined on all sides.

1.1 Each track to have a minimum base width of 3".

1.2 Leveling screws provided to ensure proper leveling for smooth operation.

1.3 Track is secured to the floor with rawl type anchors (supplied) and grouted in place.

1.4 Track sections designed with tongue and groove lap connection between each rail joint providing a smooth rail surface for ease of carriage operation.

1.5 Rail and trough drawings are available for optional recessed rail installation to make system level with the existing floor if required.

1.6 The space between the rail and the aluminum housing will be filled with a neoprene material to prevent debris from affecting carriage movement.

1.7 C and Low Pro tracks also available. Contact Customer Support for specifications.

RAISED FLOOR DECK

2.0 Standard elevated deck constructed of 3/4" plywood. Flame retardant decking is an option.

2.1 Decking shall support a minimum of 250 lbs. per square foot.

2.2 Decking to be installed flush and tight to the track.

2.3 Deck to be installed in a manner that will prevent warping, deformation and movement during normal use and operation.

2.4 Deck may be covered with floor covering as specified by the end user.

RAMPS

3.0 Beveled ramp grade shall be ADA compliant.

3.1 Ramps constructed of 3/4" plywood in 14", 18", or 24" width as determined by carriage length.

CARRIAGE

4.0 Welded steel construction; carriage side members consist of 12 gauge welded steel capable of supporting 1,000 lbs per linear carriage foot.

4.1 Fixed carriages shall be of same construction and height as movable carriages and anchored to the rails for a complete, homogeneous system.

4.2 Necessary carriage splices shall be bolted type to maintain proper unit alignment.

4.3 Carriage cross members are 12 gauge welded U-shaped steel channels.

4.4 Carriage construction to allow shelving to be securely anchored to the carriages.

WHEELS

5.0 All wheels to be a minimum of 3 1/4" in diameter, double flanged, precision ground, balanced and constructed from solid steel for smooth operation.

5.1 Each drive wheel will be fitted with two permanently sealed and shielded bearings housed in a self-aligning flanged pillow block having a dynamic load rating of 2,200 lbs. per bearing.

5.2 A minimum of four guide wheels is required per movable carriage.

DRIVE SYSTEM

6.0 All mobile carriages shall be fitted with full length drive shafts.

6.1 All drive shafts shall be a minimum of 1 1/8" hollow steel and connect all wheels on drive side of carriage. All axles shall be solid steel and support the full load of the carriage.

6.2 Complete drive shaft/axle and wheel assemblies shall be secured by means of a mechanically retained coupling method eliminating any loose connections between shafts and axles and shall exhibit no play or looseness through the length of carriage.

6.3 The mechanical assist handle shall be of ergonomic design. The transfer of power from the handle to the drive shaft shall be direct drive and chain driven.

6.4 All mechanical assist systems are to be moved by means of a chain and sprocket reduction drive system.

6.5 Mechanical assist tower attaching points shall be created using a CAM/CNC method to provide precise alignment for attachment to the carriage.

6.6 Dual control options are available for operation of mobile carriages from either or both ends.

6.7 All mechanical assist systems are equipped with a push-pull safety parking brake as a standard feature.

DRIVE EFFORT

7.0 Gear ratio to be determined by carriage length and weight; factory calculates correct drive effort for each system considering length, weight loads and number of carriages to be moved.

7.1 There is no "play" in the drive handle and the carriage will stop without drifting when operation of the actuator is terminated on all leveled systems.

END PANELS

8.0 All optional end panels are to be full height and depth of the shelving ends plus carriage height.

8.1 Melamine or high-pressure laminate covered end panels to be 3/4" in thickness.

8.2 Optional laminates are available upon customer request.

8.3 Steel chain covers or end panels may be supplied as specified. They shall cover only the exposed chain drive mechanism and mechanical assist tower or be the full height and depth of upright.

SAFETY FEATURES

9.0 All carriages can be equipped with a safety parking brake.

9.1 Carriage end stops will be provided for systems without stationary units.

9.2 A safety spacing is provided between end panels through the use of 1" carriage bumpers; protects fingers of those using the system and provides a positive stop for all carriages.

ATTACHMENT OF SHELVING

10.0 Carriage construction shall be designed to allow all shelving types to be securely anchored to the carriages. Shelving to be secured to the carriage with tek screws provided.

SYSTEM ACCESSORIES / OPTIONS

11.0 Optional security key lock systems to secure one carriage or entire system.

11.1 Back panels (for stationary units), end caps and misc. finishing pieces are available.

QUALITY CONTROL

12.0 Systems are checked at the factory to ensure high quality and uninterrupted field installation.

12.1 All parts and fasteners are provided to ensure proper and safe installation.

12.2 All mobile systems are to be installed by trained technicians.

INSTALLATION STANDARDS

13.0 Install, level and grout tracks directly to a properly prepared floor.

13.1 Install carriages, end panels (if applicable) and shelving as shown on the drawings, complete and ready for owner use.

CLEAN UP & DOCUMENTATION

14.0 All debris and excess materials resulting from installation shall be removed and the construction area left in a broom clean condition.

Additional Operators Manuals are available upon request.

DATE: OCTOBER 1, 2003
SPECIFICATIONS ARE
SUBJECT TO CHANGE

Mobile Systems Quik-Spec Specifications
1000 lb. HP5 Mechanical Assist Carriage

TTRACK

1.0 Rail to be 1/2" wide x 3/4" high # 1018 cold rolled steel rail positioned in 6063T56 "T" aluminum extrusion. Rail to be machined on all sides.

1.1 Each track to have a minimum base width of 3".

1.2 Leveling screws provided to ensure proper leveling for smooth operation.

1.3 Track is secured to the floor with rawl type anchors (supplied) and grouted in place

1.4 Track sections designed with tongue and groove lap connections between each rail joint providing a smooth rail surface for ease of carriage operation.

1.5 Rail and trough drawings are available for optional recessed rail installation to make system level with the existing floor if required.

1.6 The space between the rail and the aluminum housing will be filled with a neoprene material to prevent debris from affecting carriage movement.

1.7 C and Low Pro tracks also available. Contact Customer Support for specifications.

RAISED FLOOR DECK

2.0 Standard elevated deck constructed of 3/4" plywood. Flame retardant decking is an option.

2.1 Decking shall support a minimum of 250 lbs. per square foot.

2.2 Decking to be installed flush and tight to the track.

2.3 Deck to be installed in a manner that will prevent warping, deformation and movement during normal use and operation.

2.4 Deck may be covered with floor covering as specified by the end user.

RAMPS

3.0 Beveled ramp grade shall be ADA compliant.

3.1 Ramps constructed of 3/4" plywood in 14", 18", or 24" width as determined by carriage length.

CARRIAGE

4.0 Welded steel construction; carriage side members consist of a 5", 12 gauge C-channel design, capable of supporting minimum 1,000 lbs. per linear carriage foot.

4.1 Fixed carriages shall be of same construction and height as movable carriages and anchored to the rails for a complete, homogeneous system.

4.2 Necessary carriage splices shall be a bolted type to maintain proper unit alignment

4.3 Carriage cross members are 12 gauge, welded U-shaped steel channels with extra reinforcement when specified for X-Ray shelving.

4.4 Carriage construction to allow shelving to be securely anchored to the carriages.

WHEELS

5.0 All wheels to be a minimum of 5" in diameter, double flanged, precision ground, balanced and constructed from solid steel for smooth operation.

5.1 Each drive wheel will be fitted with two permanently sealed and shielded bearings housed in a self-aligning flanged pillow block having a dynamic load rating of 2,200 lbs. per bearing.

5.2 A minimum of four guide wheels is required per movable carriage.

DRIVE SYSTEM

6.0 All mobile carriages shall be fitted with full length drive shafts.

6.1 All drive shafts shall be a minimum of 1 1/8" hollow steel tubing and connect all wheels on drive side of carriage. All axles shall be solid steel and support the full load of bearings.

6.2 Complete drive shaft / axle and wheel assemblies shall be secured by means of a mechanically retained coupling method eliminating any loose connections between shafts and axles and shall exhibit no play or looseness through the length of carriage.

6.3 The mechanical assist handle shall be of ergonomic design. The transfer of power from the handle to the drive shaft shall be direct drive and chain driven.

6.4 All mechanical assist systems are to be moved by means of a chain and sprocket reduction drive system.

6.5 Mechanical assist tower attaching points shall be created using a CAM/CNC method to provide precise alignment for attachment to the carriage.

6.6 Dual control options are available for operation of mobile carriages from either or both ends.

6.7 All mechanical assist systems are equipped with a push-pull safety parking brake as a standard feature.

DRIVE EFFORT

7.0 Gear ratio to be determined by carriage length and weight; factory calculates correct drive effort for each system considering length, weight loads and number of carriages to be moved.

7.1 There shall be no "play" in the drive handle and the carriage shall stop without drifting when operation of the actuator is terminated on all leveled systems.

END PANELS

8.0 All optional end panels are to be the full height and depth of the shelving ends plus carriage height.

8.1 Melamine or high pressure laminate covered end panels to be 3/4" in thickness.

8.2 Optional laminates are available upon customer request.

8.3 Steel chain covers or end panels may be supplied as specified. They shall cover only the exposed chain drive mechanism and mechanical assist tower or be the full height and depth of upright.

SAFETY FEATURES

9.0 All carriages are equipped with a safety parking brake

9.1 Carriage end stops will be provided for systems without stationary units.

9.2 A safety spacing is provided between end panels through the use of 1" carriage bumpers; protects fingers of those using the system and provides a positive stop for all carriages.

ATTACHMENT OF SHELVING

10.0 Carriage construction shall be designed to allow all shelving types to be securely anchored to the carriages. Shelving to be secured to the carriage with (enclosed) special tek screws

SYSTEM ACCESSORIES / OPTIONS

11.0 Optional security key lock to secure one carriage or entire system.

11.1 Back panels (for stationary units), end caps and misc. finishing pieces are available.

11.2 Optional label holders show aisle contents.

QUALITY CONTROL

12.0 Systems are checked at the factory to ensure high quality and an uninterrupted field installation.

12.1 All parts and fasteners are provided to ensure proper and safe installation.

12.2 All mobile systems are to be installed by trained technicians.

INSTALLATION STANDARDS

13.0 Install, level and grout tracks directly to a properly prepared floor.

13.1 Install carriages, end panels (if applicable) and shelving as shown on the drawings, complete and ready for owner use.

CLEAN UP & DOCUMENTATION

14.0 All debris and excess materials resulting from installation shall be removed and the construction area left in a broom clean condition.

Additional Operator Manuals are available upon request.

DATE: OCTOBER 1, 2003
SPECIFICATIONS ARE
SUBJECT TO CHANGE

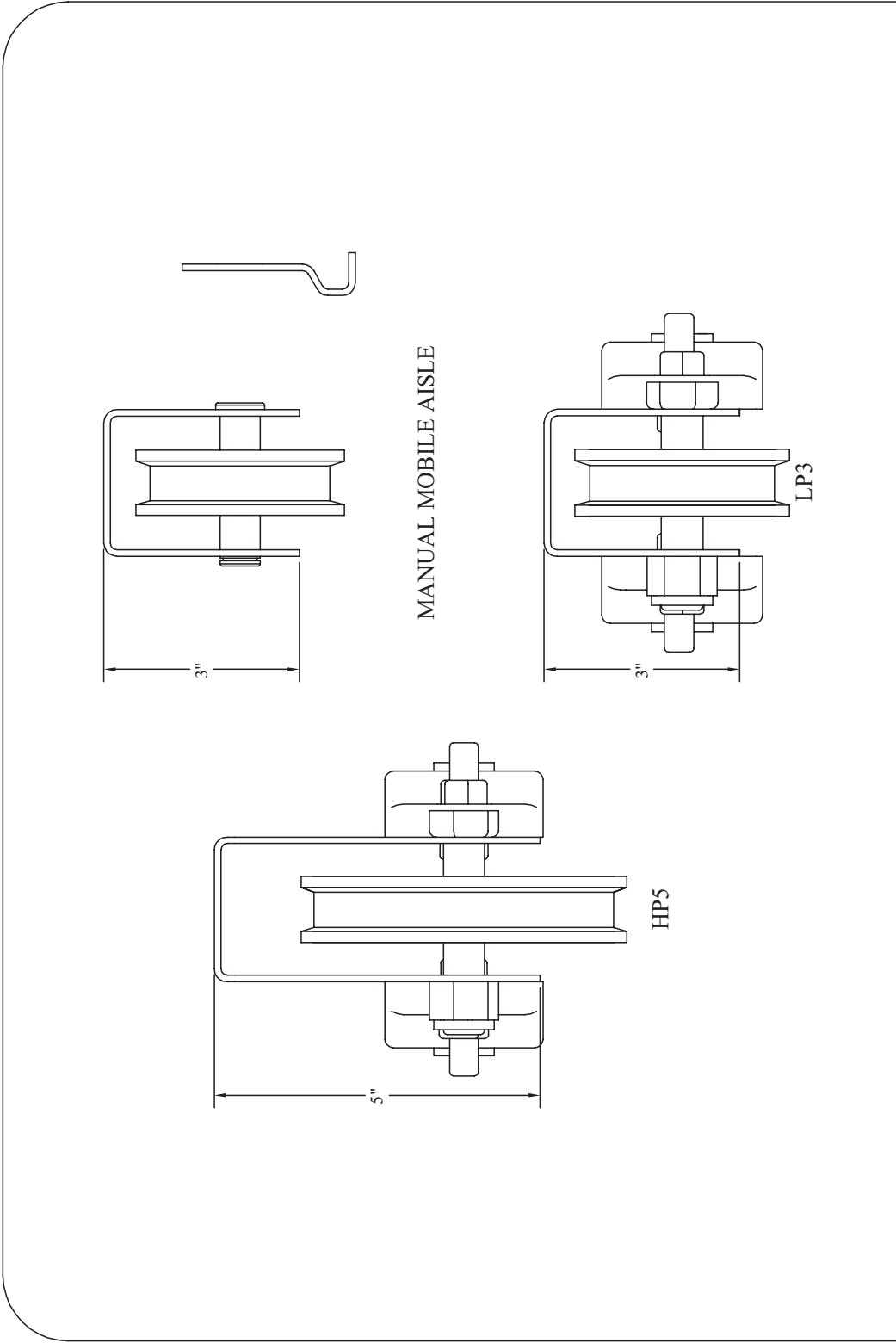

ALL DESIGNS REPRESENTED BY THIS DRAWING ARE CONFIDENTIAL AND SHOULD NOT BE DISCLOSED WITHOUT WRITTEN PERMISSION FROM DIRECT LINE

TITLE:	CARRIAGE SADDLE PROFILES		
FILE:	CARRIAGE PROFILES.DWG	REVISION:	00
SCALE:	NONE	DRAWN BY:	MED
DATE:	04/17/2001		

DIRECT LINE
CORPORATION

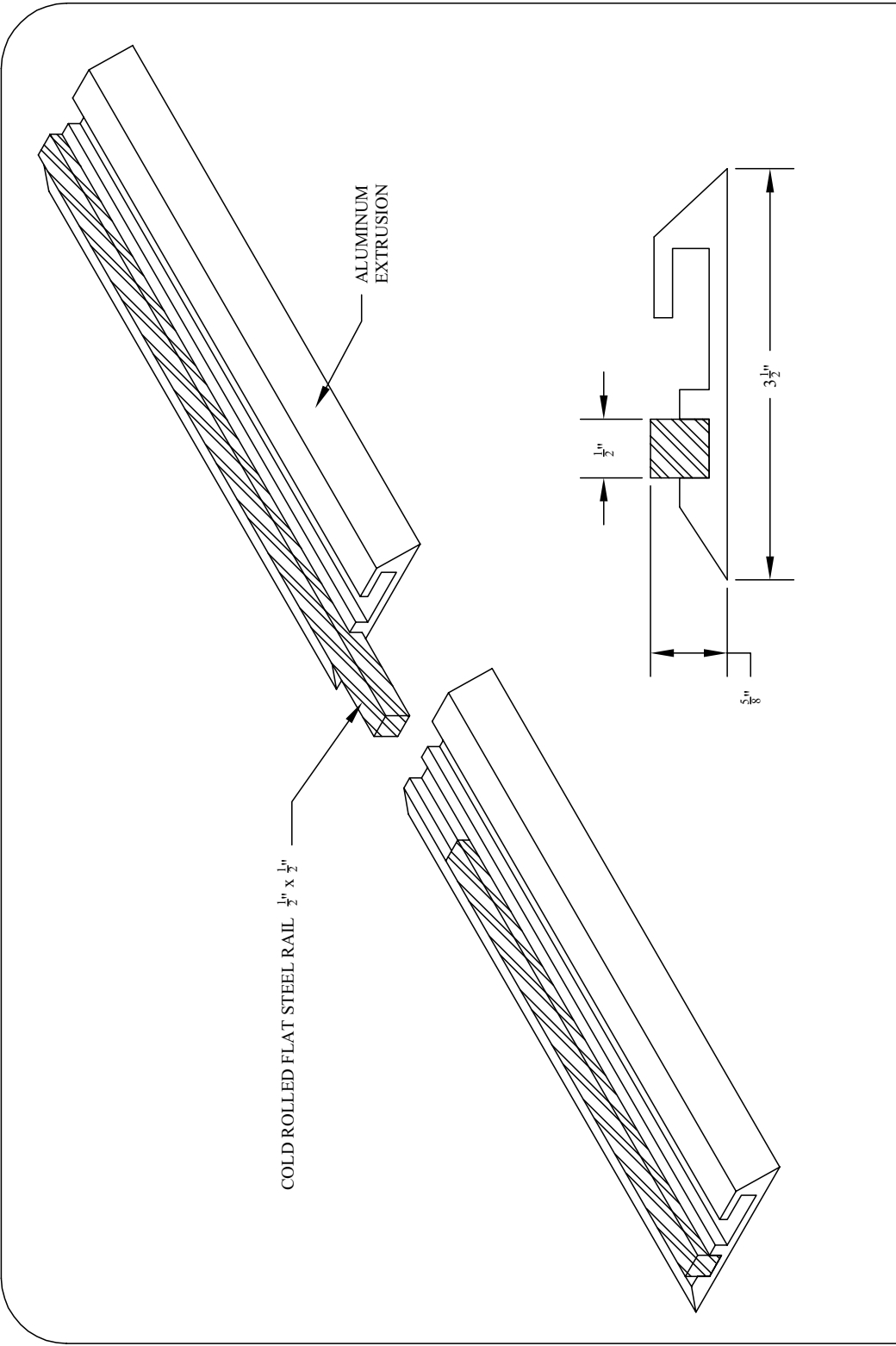

ALL DESIGNS REPRESENTED BY THIS DRAWING ARE CONFIDENTIAL AND SHOULD NOT BE DISCLOSED WITHOUT WRITTEN PERMISSION FROM DIRECT LINE

TITLE:	C TRACK		
FILE:	5718DL.DWG	REVISION:	00
SCALE:	NONE	DRAWN BY:	MED
DATE:	04/09/2001		

DIRECT LINE
CORPORATION

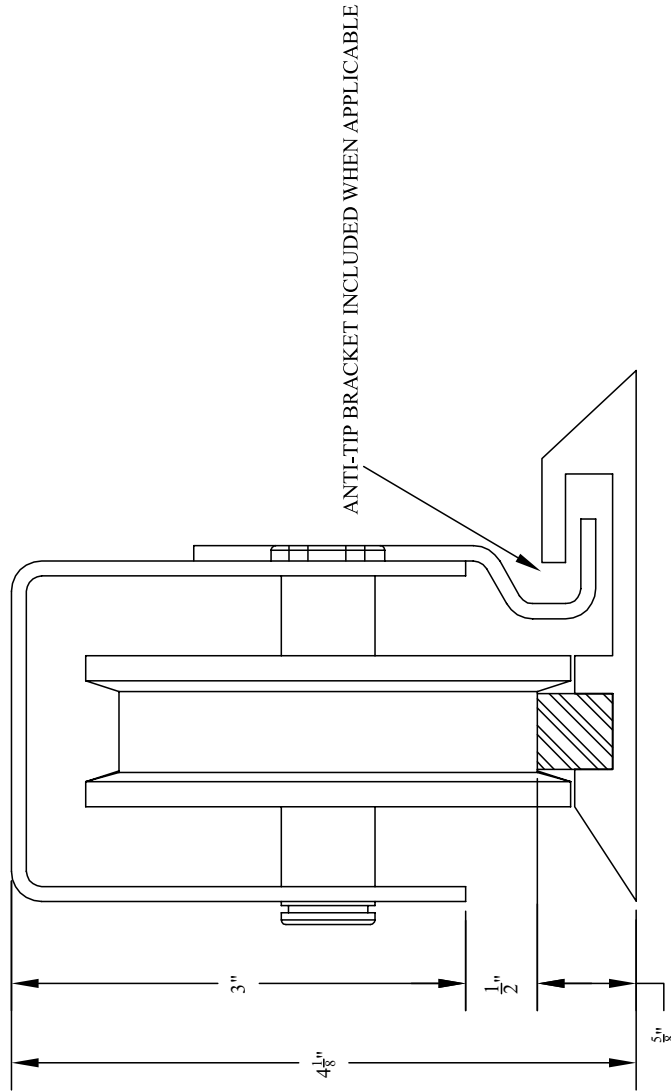

**3" Carriage Manual Mobile
and
Lateral Carriages after 4/15/03**

ALL DESIGNS REPRESENTED BY THIS DRAWING ARE CONFIDENTIAL AND SHOULD NOT BE DISCLOSED WITHOUT WRITTEN PERMISSION FROM DIRECT LINE

TITLE:	6001DL - C TRACK WITH 3" WHEELS		
FILE:	6001DL-C.DWG	REVISION:	00
SCALE:	NONE	DRAWN BY:	MED
DATE:	04/09/2001		



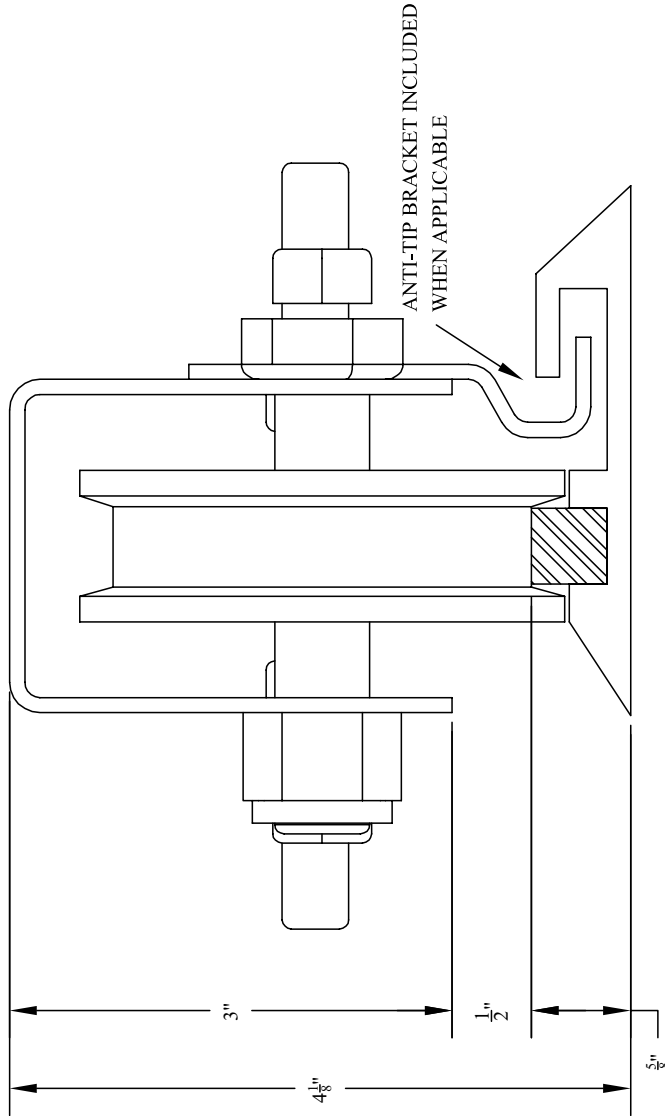

Mechanical Assist LP3 Carriage

ALL DESIGNS REPRESENTED BY THIS DRAWING ARE CONFIDENTIAL AND SHOULD NOT BE DISCLOSED WITHOUT WRITTEN PERMISSION FROM DIRECT LINE

TITLE:	6002DL - LP3 CARRIAGE - C TRACK		
FILE:	6002DL-C.DWG	REVISION:	00
SCALE:	NONE	DRAWN BY:	MED
DATE:	04/09/2001		



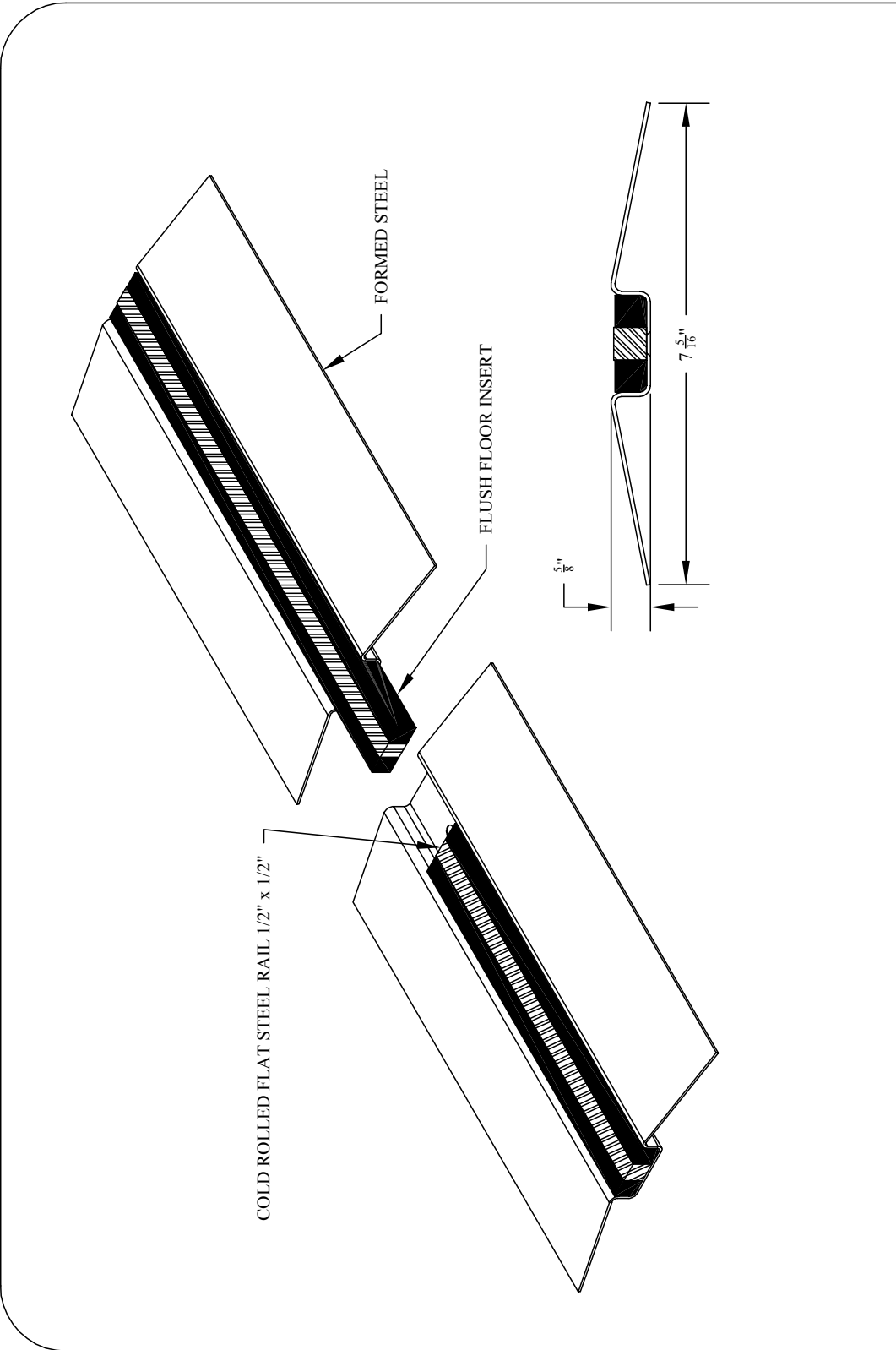

ALL DESIGNS REPRESENTED BY THIS DRAWING ARE CONFIDENTIAL AND SHOULD NOT BE DISCLOSED WITHOUT WRITTEN PERMISSION FROM DIRECT LINE

TITLE: LOW PRO TRACK	
FILE: 5717DL.DWG	REVISION: 00
SCALE: NONE	DRAWN BY: MED
DATE: 04/08/2001	



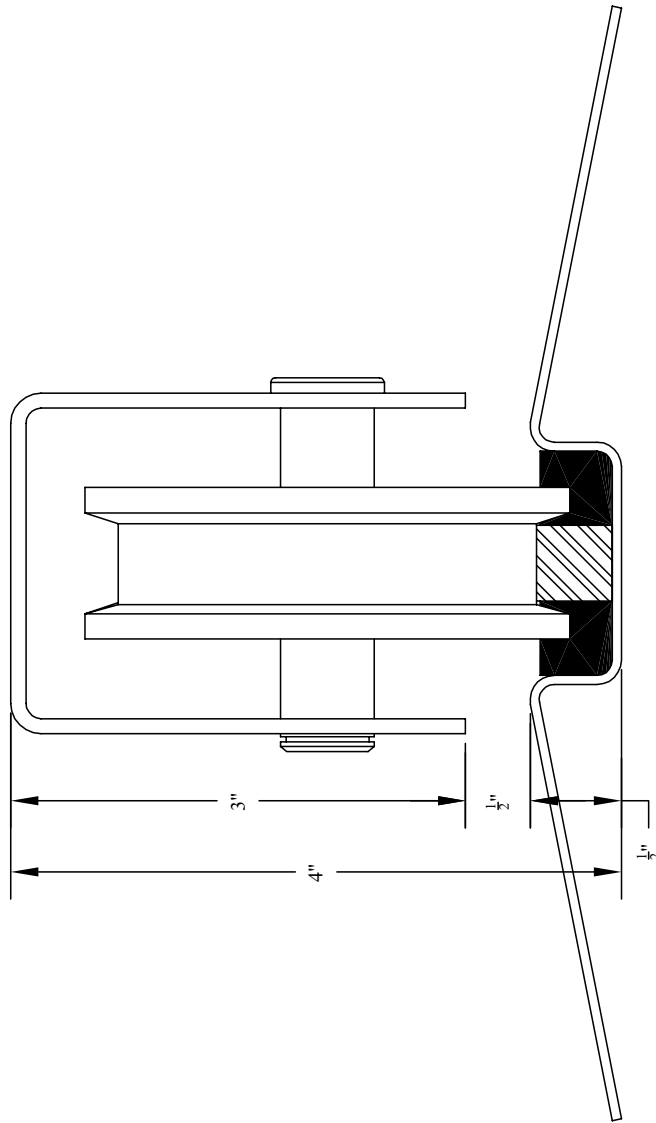

Manual Mobile

ALL DESIGNS REPRESENTED BY THIS DRAWING ARE CONFIDENTIAL AND SHOULD NOT BE DISCLOSED WITHOUT WRITTEN PERMISSION FROM DIRECT LINE

TITLE:	6001DL - LOW-PRO TRACK WITH 3" WHEELS		
FILE:	6001DL-L.DWG	REVISION:	00
SCALE:	NONE	DRAWN BY:	MED
DATE:	04/08/2001		

DIRECT LINE
CORPORATION

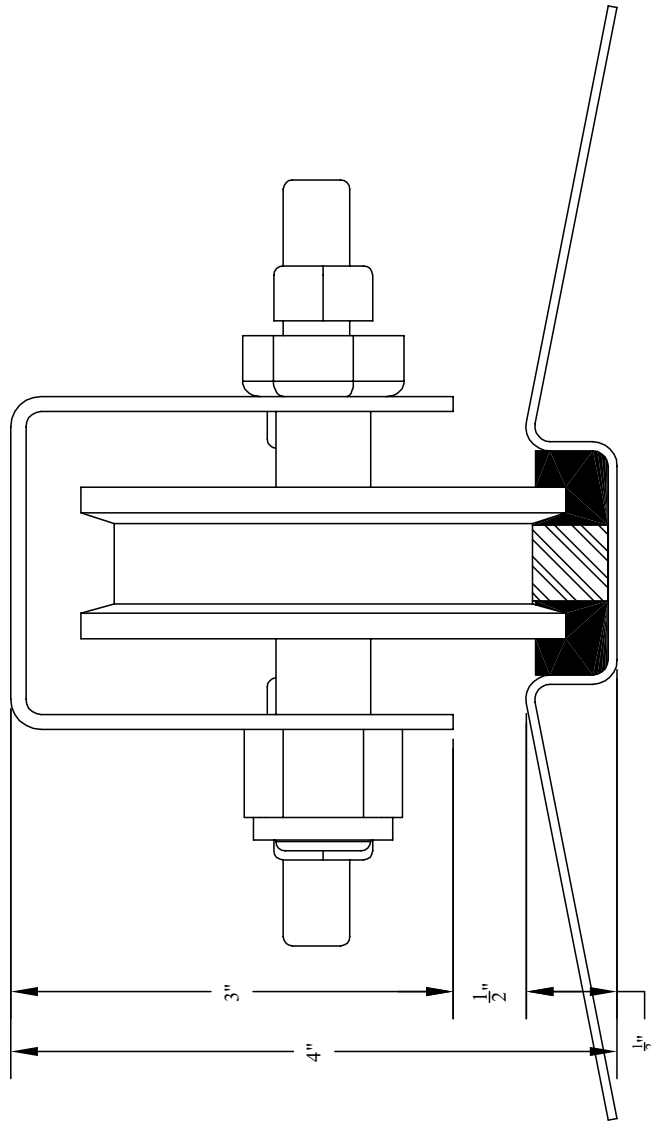

Mechanical Assist LP3 Carriage

ALL DESIGNS REPRESENTED BY THIS DRAWING ARE CONFIDENTIAL AND SHOULD NOT BE DISCLOSED WITHOUT WRITTEN PERMISSION FROM DIRECT LINE

TITLE:	6002DL - LP3 CARRIAGE - LOW-PRO TRACK		
FILE:	6002DL-L.DWG	REVISION:	00
SCALE:	NONE	DRAWN BY:	MED
DATE:	04/08/2001		



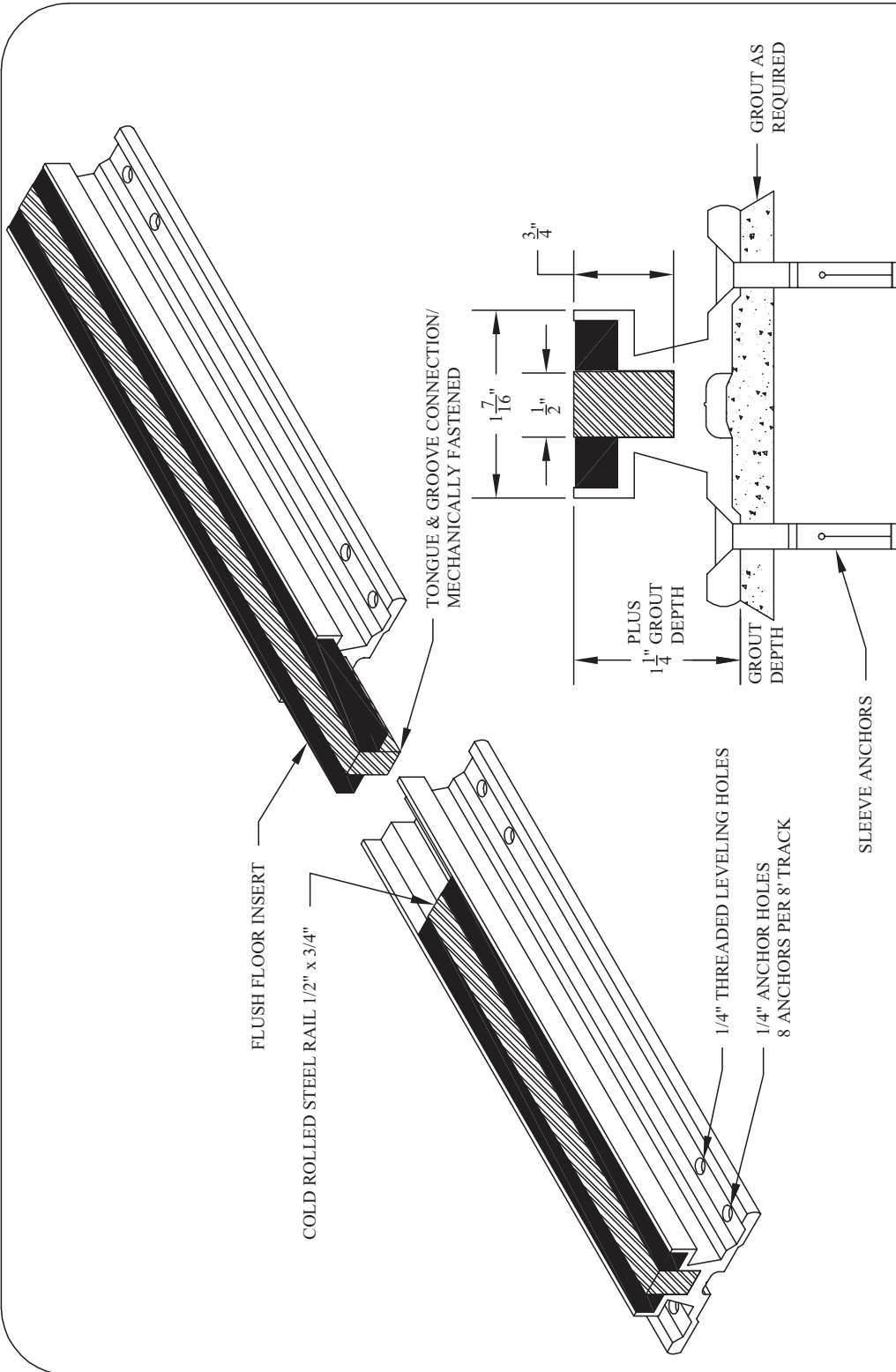

ALL DESIGNS REPRESENTED BY THIS
DRAWING ARE CONFIDENTIAL AND
SHOULD NOT BE DISCLOSED
WITHOUT WRITTEN PERMISSION
FROM DIRECT LINE

TITLE:	T-TRACK WITH GROUT AND ANCHORS		
FILE:	5711DL.DWG	REVISION:	01
SCALE:	NONE	DRAWN BY:	MED
DATE:	02/07/2002		

DIRECTLINE

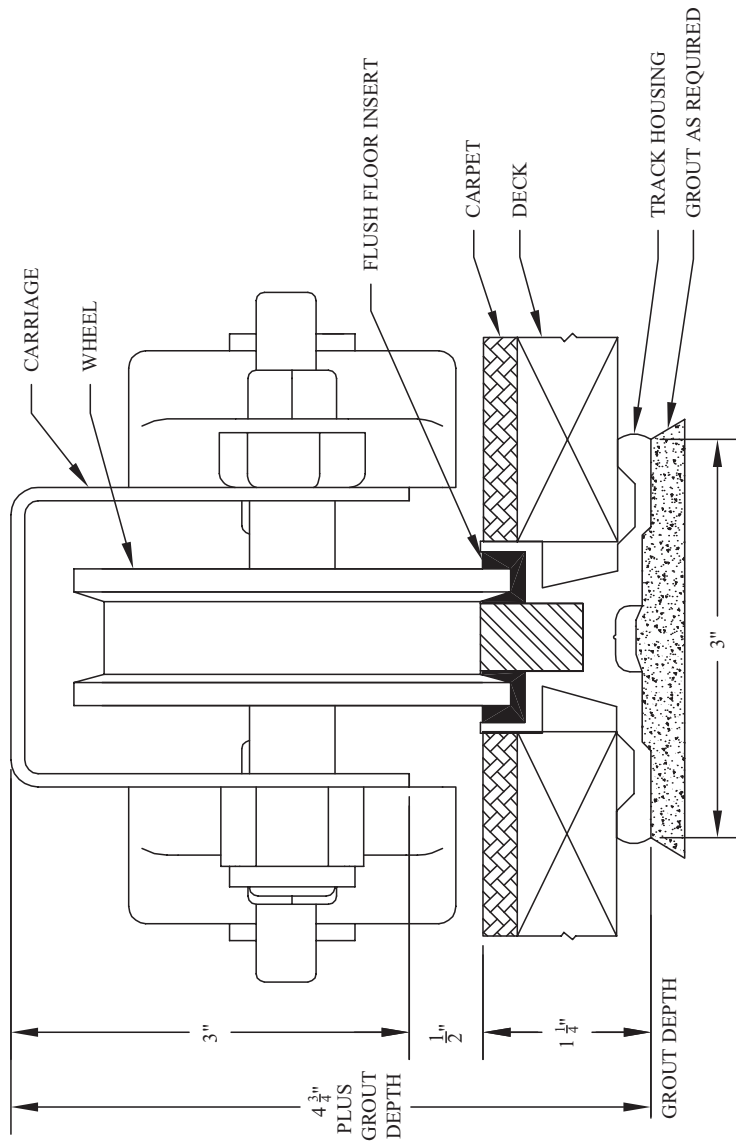

ALL DESIGNS REPRESENTED BY THIS DRAWING ARE CONFIDENTIAL AND SHOULD NOT BE DISCLOSED WITHOUT WRITTEN PERMISSION FROM DIRECT LINE

TITLE:	6003DL - LP3 CARRIAGE - T TRACK WITH GROUT	REVISION:	00
FILE:	6003DL.DWG	DRAWN BY:	MED
SCALE:	NONE	DATE:	04/17/2001

DIRECT LINE
CORPORATION

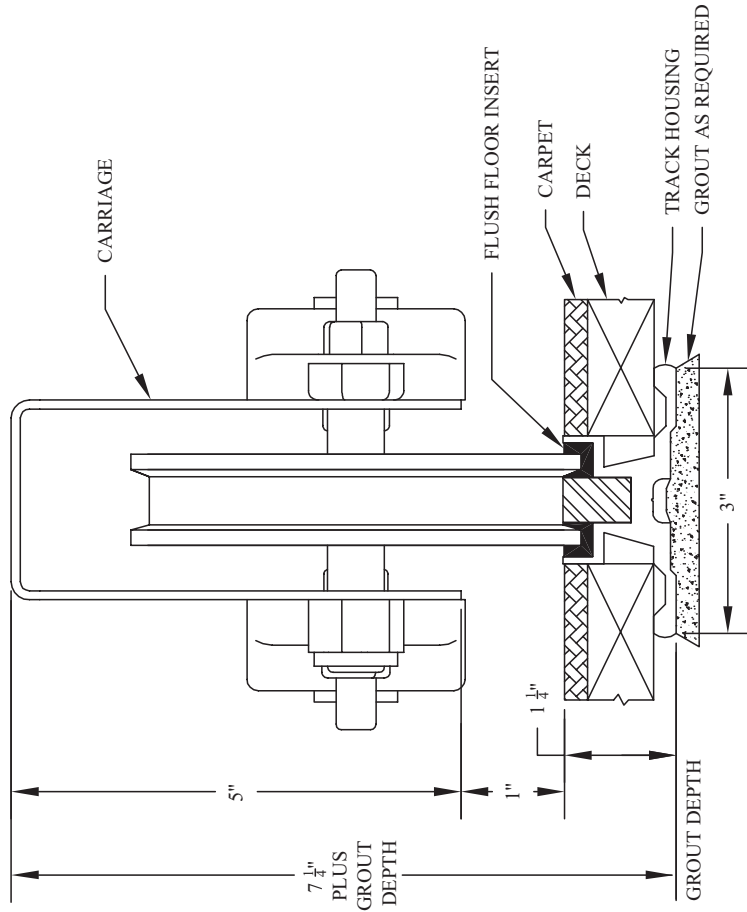

ALL DESIGNS REPRESENTED BY THIS DRAWING ARE CONFIDENTIAL AND SHOULD NOT BE DISCLOSED WITHOUT WRITTEN PERMISSION FROM DIRECT LINE

TITLE:	6004DL - HP5 CARRIAGE - T TRACK WITH GROUT	REVISION:	00
FILE:	6004DL.DWG	DRAWN BY:	MED
SCALE:	NONE	DATE:	04/09/2001

DIRECT LINE
CORPORATION

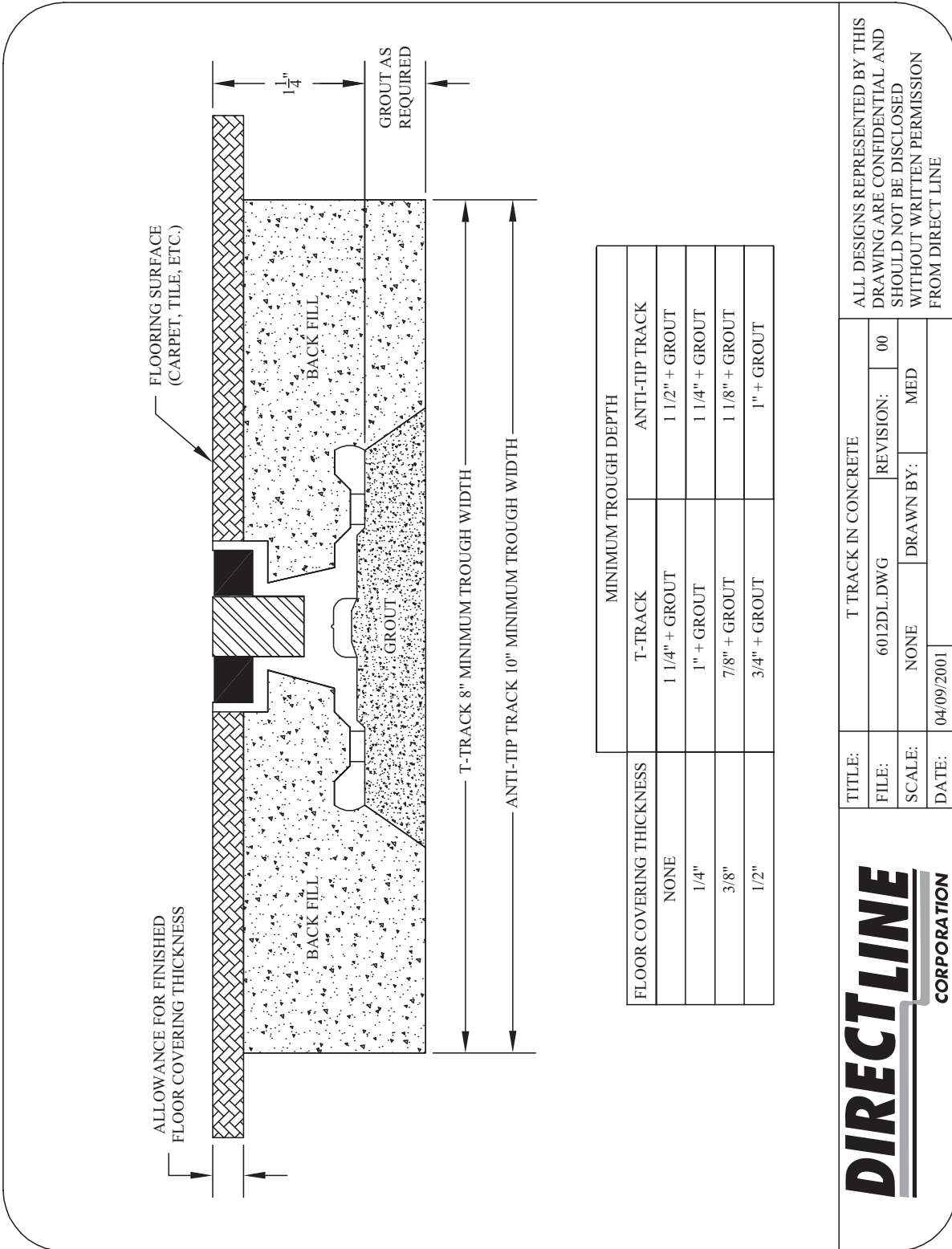

FLOOR COVERING THICKNESS	MINIMUM TROUGH DEPTH	
	T-TRACK	ANTI-TIP TRACK
NONE	1 1/4" + GROUT	1 1/2" + GROUT
1/4"	1" + GROUT	1 1/4" + GROUT
3/8"	7/8" + GROUT	1 1/8" + GROUT
1/2"	3/4" + GROUT	1" + GROUT

DIRECT LINE CORPORATION

TITLE: T TRACK IN CONCRETE
 FILE: 6012DL.DWG REVISION: 00
 SCALE: NONE DRAWN BY: MED
 DATE: 04/09/2001

ALL DESIGNS REPRESENTED BY THIS DRAWING ARE CONFIDENTIAL AND SHOULD NOT BE DISCLOSED WITHOUT WRITTEN PERMISSION FROM DIRECT LINE

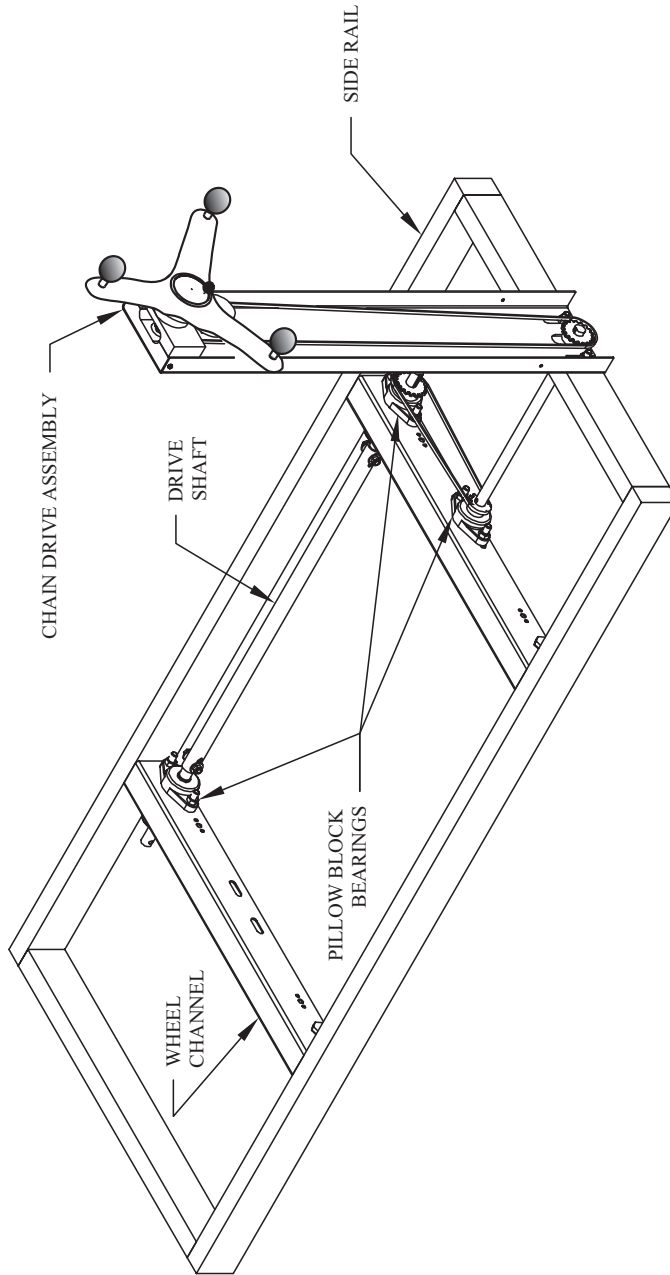

ALL DESIGNS REPRESENTED BY THIS DRAWING ARE CONFIDENTIAL AND SHOULD NOT BE DISCLOSED WITHOUT WRITTEN PERMISSION FROM DIRECT LINE

TITLE:	LP3 CARRIAGE	
FILE:	7004DL.DWG	REVISION: 00
SCALE:	NONE	DRAWN BY: MED
DATE:	04/08/2001	

DIRECT LINE
CORPORATION

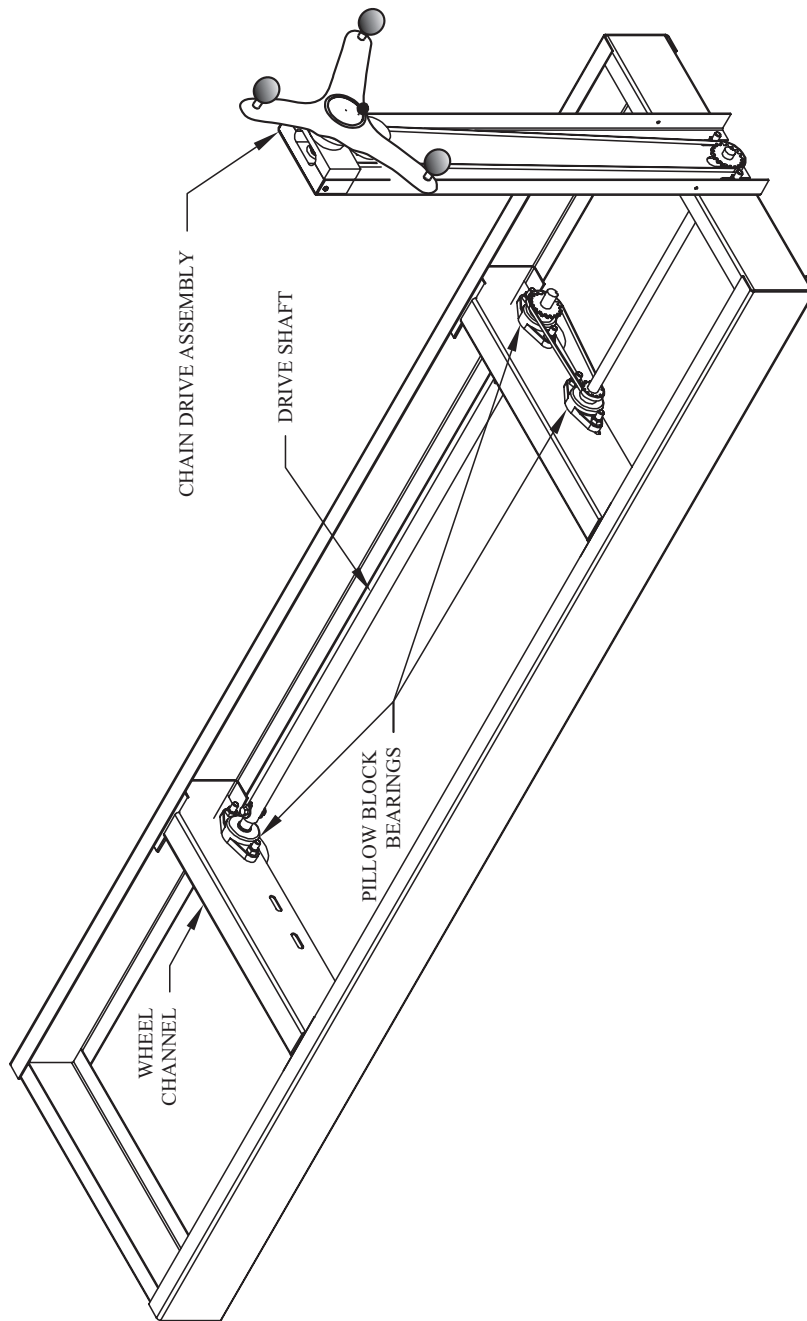

ALL DESIGNS REPRESENTED BY THIS DRAWING ARE CONFIDENTIAL AND SHOULD NOT BE DISCLOSED WITHOUT WRITTEN PERMISSION FROM DIRECT LINE

TITLE:	HP5 CARRIAGE		
FILE:	7005DL.DWG	REVISION:	00
SCALE:	NONE	DRAWN BY:	MED
DATE:	04/08/2001		

DIRECT LINE
CORPORATION

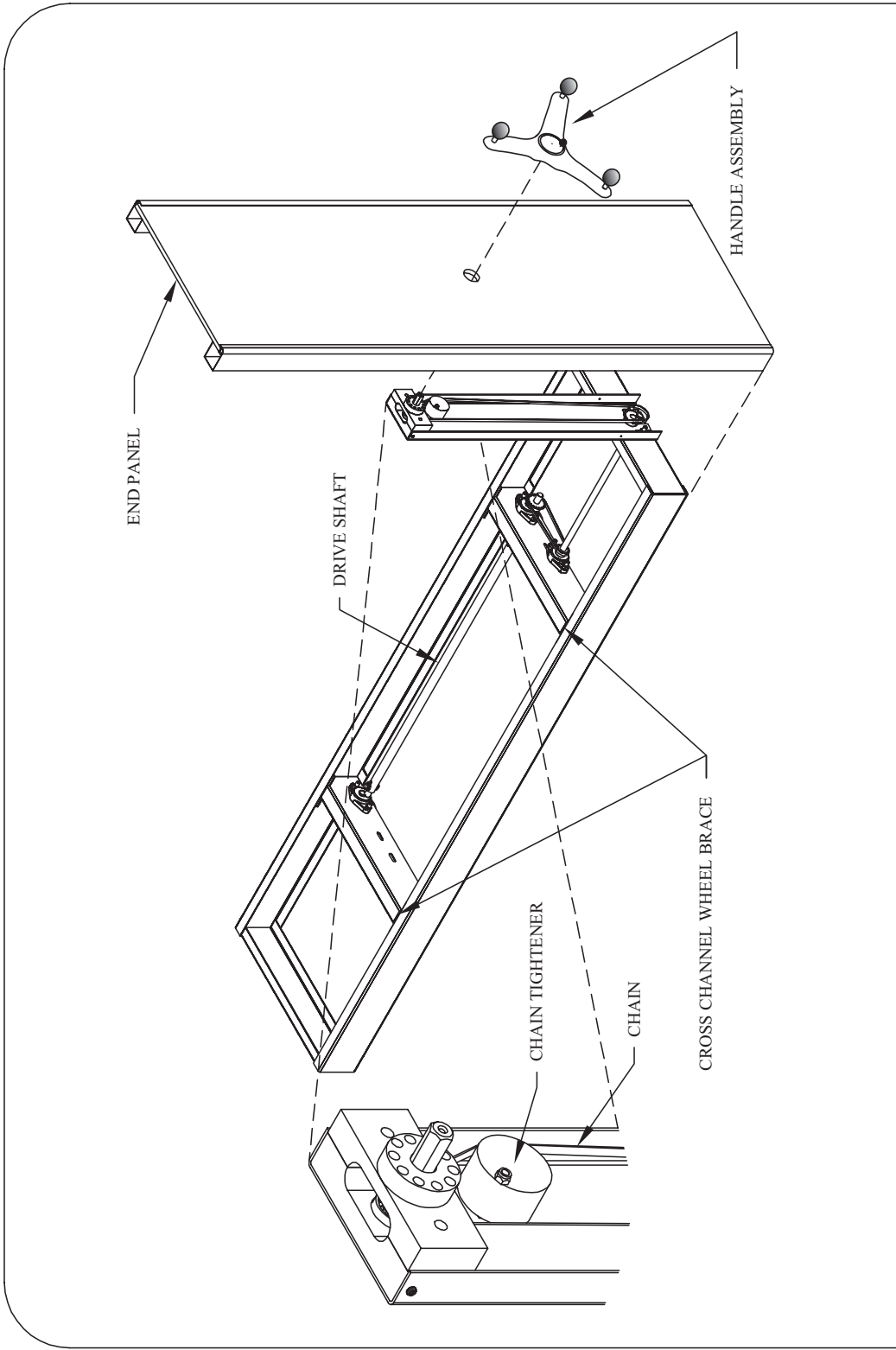

ALL DESIGNS REPRESENTED BY THIS DRAWING ARE CONFIDENTIAL AND SHOULD NOT BE DISCLOSED WITHOUT WRITTEN PERMISSION FROM DIRECT LINE

TITLE:	END PANEL ASSEMBLY PROFILE		
FILE:	700IDL.DWG	REVISION:	00
SCALE:	NONE	DRAWN BY:	MED
DATE:	04/08/2001		

