

Space PRO[®]

Manual and
Mechanical Assist Systems

Installation Manual

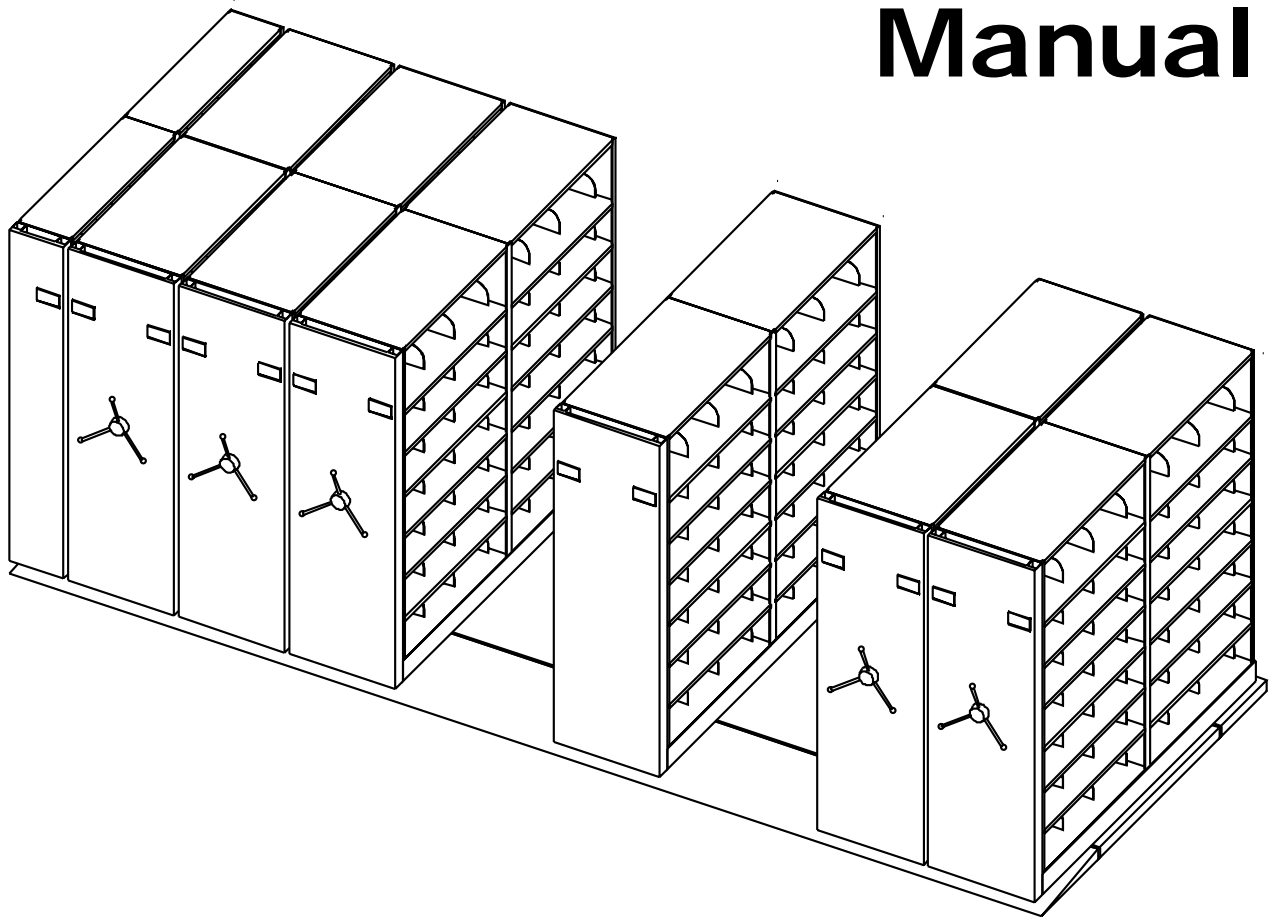

DIRECTLINE
CORPORATION

March 15, 2001

Installer's Tool List

25'+ tape measure
5/16" and Tek driver bits
Broom
Chalk line
Circular saw with blades
Dewalt type variable speed drill
Extension Cords (3 prong)
Grout mixing paddle, water bucket, trowels
Hammers
Hilti-type hammer drill
Laser level
Torpedo level
Rail spacers (available for purchase from Direct Line)
Rubber gloves
Safety glasses
Set of allen wrenches
Set of open-end wrenches
Utility knives with replacements blades
Vacuum Cleaner

DIRECTLINE
CORPORATION

Telephone #: 1-800-822-4000
Fax #: 1-703-234-0337
P.O. Box 1759, Sterling, VA 20167

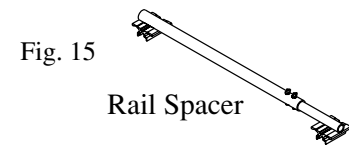
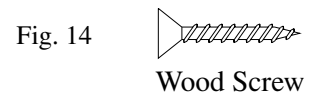
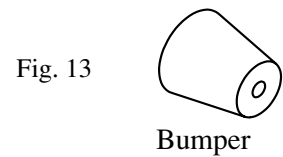
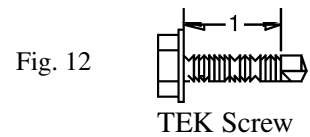
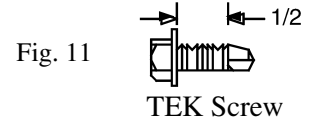
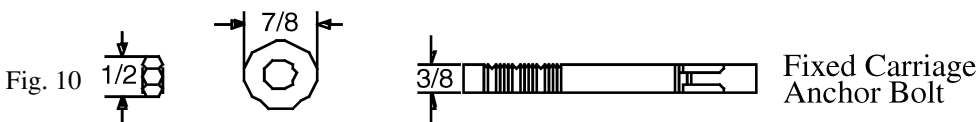
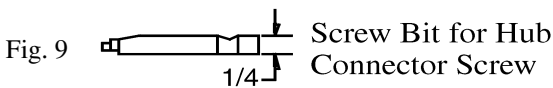
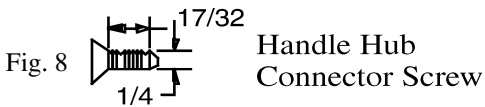
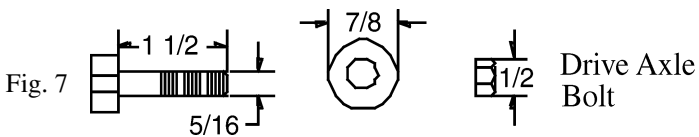
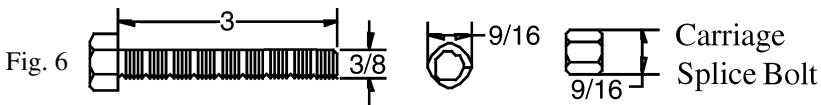
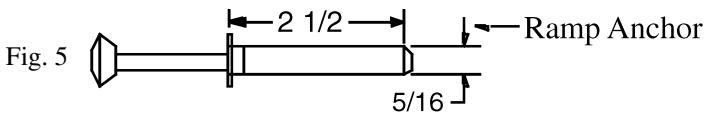
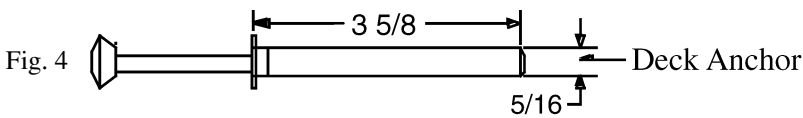
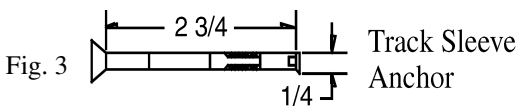
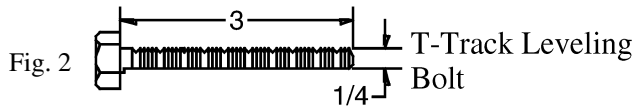
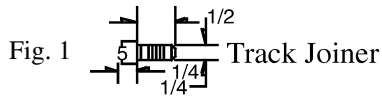

T-Track or Seismic Track on Concrete Floor

- Make sure carpet is removed and space is clean where mobile system is to be installed.
- Position tracks approximately on floor per system drawing.
- Connect tracks together at splice joints with track joiner screw. (See page 3, Fig. 1)
- Use a chalk line to position first track approximately 2" off back wall.?????????
- Install the track leveling bolts (3 bolts per side of 8' of track). (See page 3, Fig. 2)
- Measure and/or use track spacers (available for purchase from Direct Line) to locate tracks in their final position. (See Page 3, Fig. 15)
- Use laser/transit level and adjust track leveling bolts. ***Tracks must be finished level with a "minimum" of 1/2" above the highest point of the existing floor.***
- Once tracks are in place and level, drill 5/16" holes making sure holes are deep enough for the 2 3/4" track sleeve anchors. (See page 3, Fig. 3) There are 6 anchor holes per 8' piece of track.
- Install sleeve anchors through track and into floor, ***but do not tighten at this time. Go back and check all measurements and track levelness in length and width of installation. Adjust leveling bolts as needed.***
- Tighten all anchors.
- Grout under track.
- Remove all track leveling bolts after grout has set.

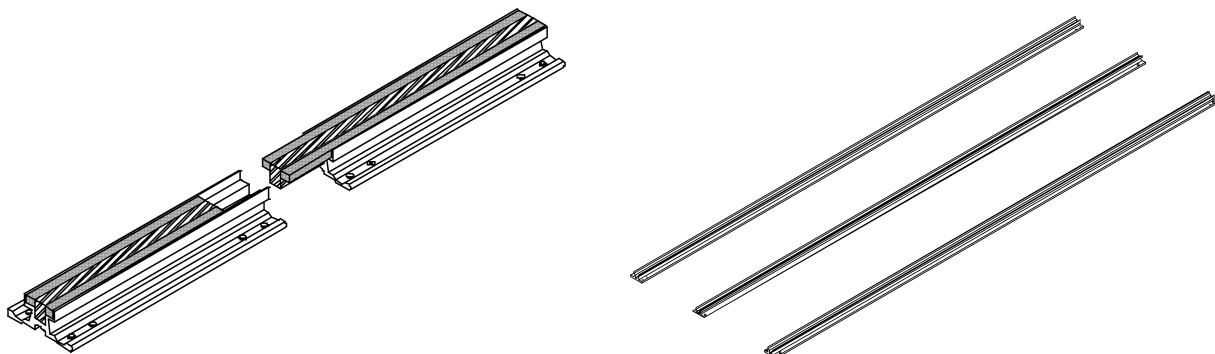

Installing the "G," LoPro and "C" Tracks

- Position tracks on floor (approximately) per system drawing.
- Connect tracks together at splice joints with track joiner screws. (See page 3. Fig. 2)
- Use a chalk line to position first track from back wall, **adding** an additional 2" to accommodate for variations in back wall.
- Shim/level and/or position tracks for final attachment. (Track Spacers may be used on "C" and LowPro tracks only).

Once tracks are in place:

...if "G" Track

- Mark position of tracks on floor with tape or marker.
- Position a carriage on tracks and assure smooth movement before final attachment.
- Pull tape off bottom of track one foot (1 ft.) at a time, pressing down on track as you go, maintaining proper alignment.
- Place all carriages on tracks and move several times securing track placement.

...if "LoPro" Track

- Mark position of tracks on floor with tape or marker.
- Position a carriage on tracks and assure smooth movement before final attachment.
- Pull tape off bottom of track one foot (1 ft.) at a time, pressing down on track as you go, maintaining proper alignment.
- Place all carriages on tracks and move several times securing track placement.
- Install neoprene on both sides of rail.

If preferable attach tracks to floor as done in "G" LoPro track below.

...if "C" Track

- Mark position of tracks on floor with tape or marker.
- Level tracks and if applicable, use shims to fill any low spots preventing track deflection.
- Position a carriage on tracks and assure smooth movement before final attachment.
- Drill $\frac{5}{16}$ " holes into flooring using pre-existing pilot holes in tracks as guides. Assure holes are a minimum 2" deep to allow for sleeve anchors.
- Secure tracks with enclosed hardware.

If preferable attach tracks to floor as done in "A" and "LowPro" tracks above.

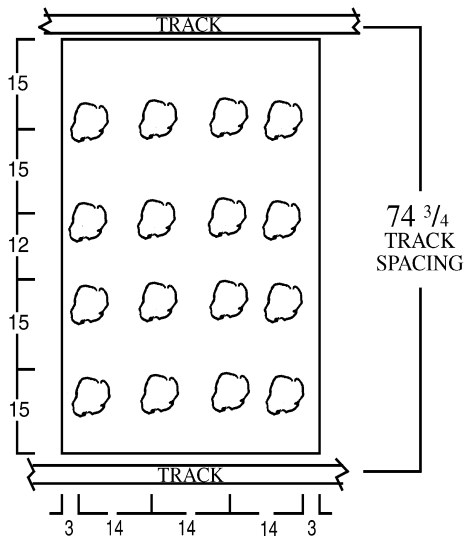
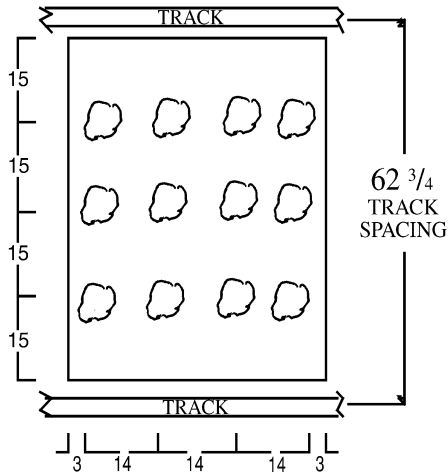
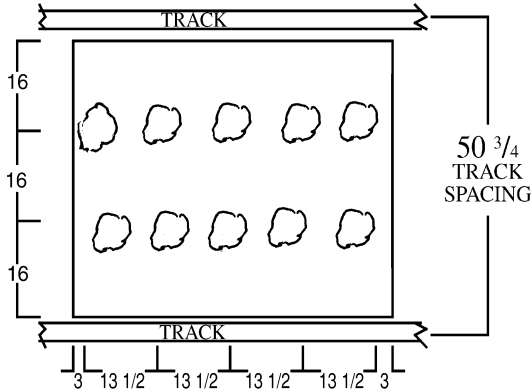

Deck

- All decking systems must be supported. Direct Line recommends the grout support concept described below.
- Mix grout and form into snowballs approximately 3-4" in diameter.
- Place the grout balls onto the floor per the designed choice in drawings at left.
- Before grout dries take the tube leveler, (See page 3, Fig. 12) extend to proper length and roll out (and flatten) tops of grout balls.
- When grout balls dry, lay out decking. *When installing decking consult enclosed drawings for proper layout.*
- Drill into decking and concrete flooring with hammerdrill and install 3 ⁵/₈" anchors. (See page 3, Fig. 4) Try to position anchors away from grout balls (roughly 8 anchors per deck section)
- Secure ramp with same procedure using the 2 ⁵/₈" anchors. (See page 3, Fig. 5)
- After decking and ramp have been installed, sweep decking and carefully vacuum all tracks.
- Install neoprene track fillers on both sides of all rails.

Carriages

- Carriages longer than 8' are shipped in sections and must be bolted together.
- Carriage sections are labeled with alpha and numeric indicators, i.e., 1A connects to 1A and 2B connects to 2B, etc. The number is the carriage, and the letters, the splice designation.
- Slide the 1 1/8" tubular drive shaft in place over the axle. Do not bolt in place at this time.
- Bolt carriages together with 3" carriage splice bolts. (See page 3, Fig. 6)
- Bolt the drive shaft in place with drive axle bolts. (See page 3, Fig. 7)
- Install bumpers (2 per carriage) in pre-drilled holes. (See page 3, Fig. 13)
- When installing fixed carriages, place carriage on rail. Drill through bracket holes with hammerdrill into concrete floor and secure carriage with fixed carriage anchor bolt (See page 3, Fig. 10)

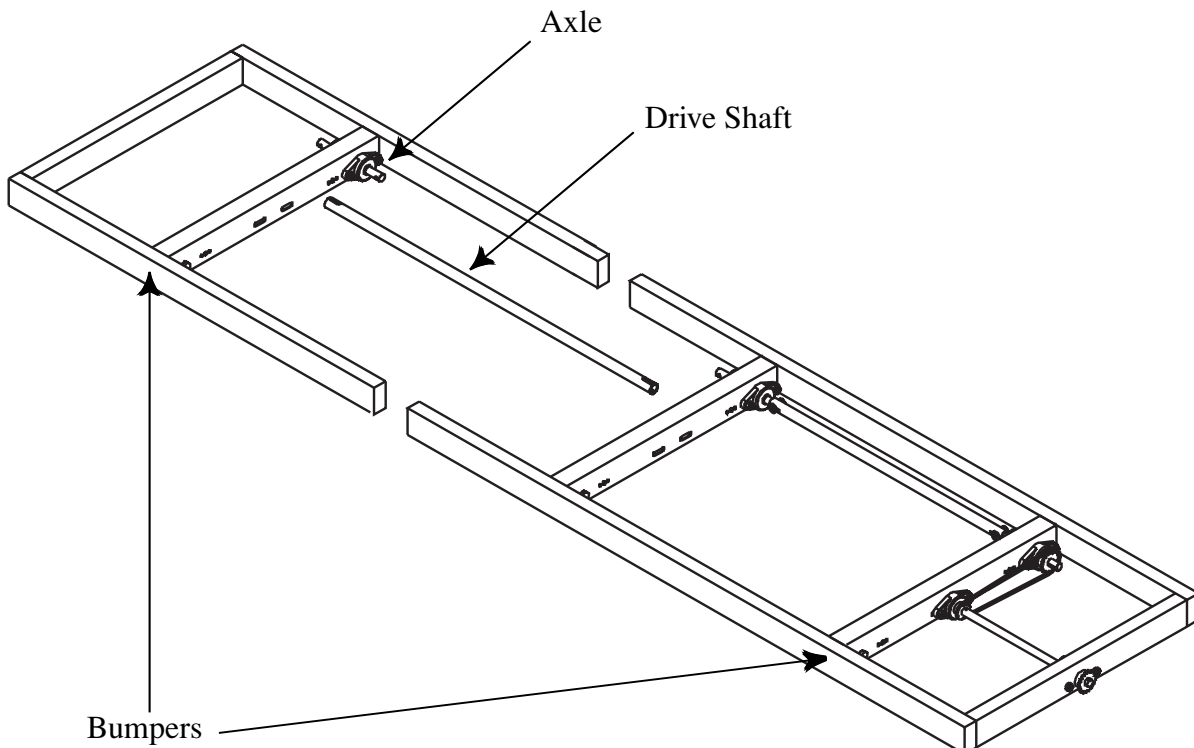

Mechanical Assist Chain Guard

- Loosen the two nuts (A & B) located on the front end of carriage. (Dwg. 8.2)
- Lower the chain guard **over** carriage tab to facilitate placement of chain on sprocket.
- Mount the chain guard assembly on the front of the carriage in a manner to allow you to put the chain over the sprocket.
- Raise chain guard and rest on carriage tab. (Dwg. 8.2)
- Secure chain guards by tightening bolts A & B.
- Loosen the nut on the nylon adjustment cam located inside the chain guard. Rotate the cam *counterclockwise* to set chain tension. Tighten nut. (Dwg. 8.1)

Dwg. 8.1

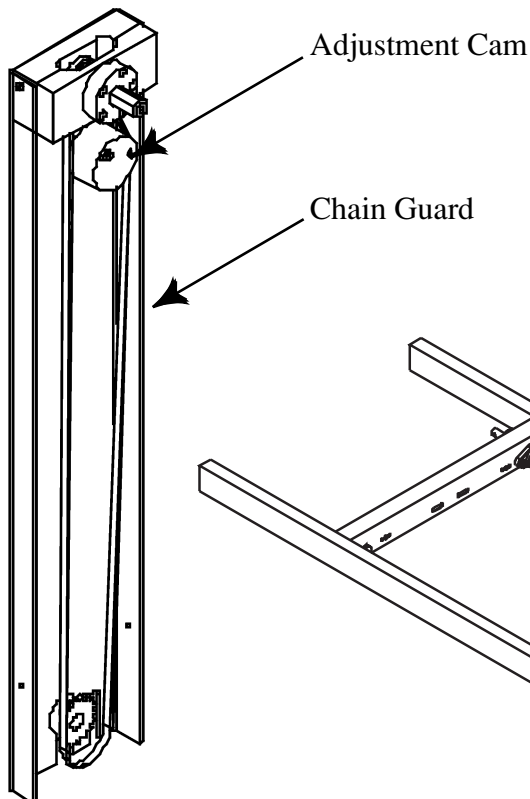

Dwg. 8.2

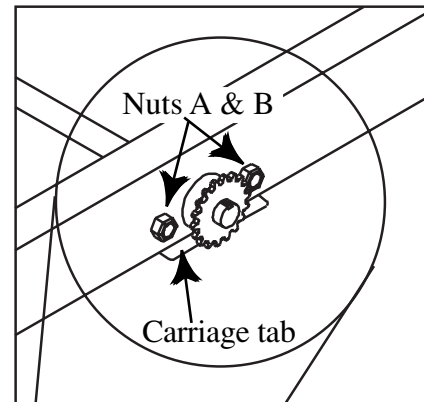

Attachment of Chain Guard to 4 Post Shelving

- Position chain guard support (Dwg. 9.1) behind closed upright as close to the top of the chain guard as possible. (Dwg. 9.2)
- Fasten chain guard to the support with two 1/2" Tek screws through C-Channel from inside the shelving. The flat portion of the C-Channel rests against the shelving. (See page 3, Fig. 12)

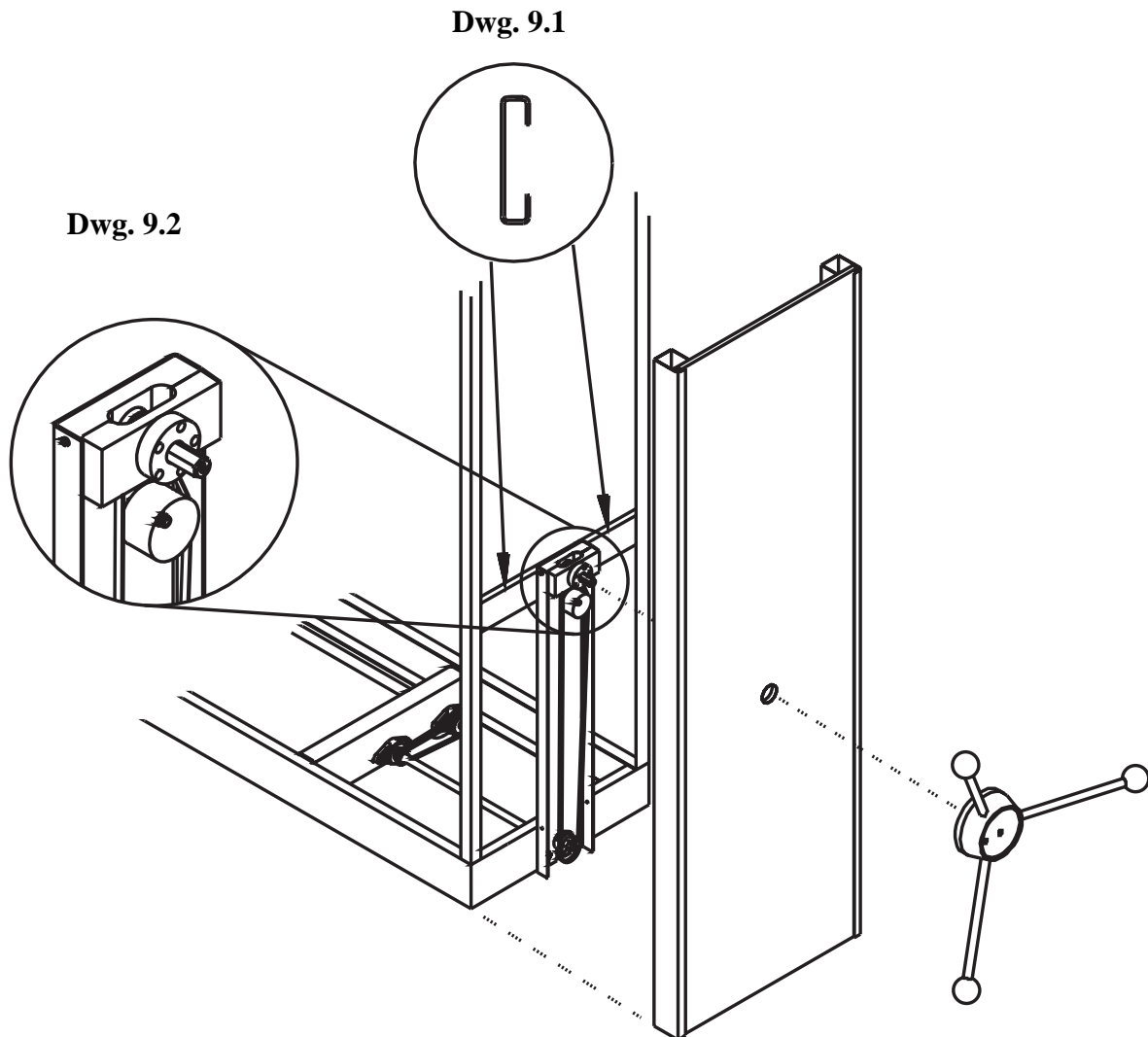

End Panel Options

NOTE: All End Panel fastener hardware is provided and found in designated “hardware box”

Chain Guard Only

- Position cover over chain guard and attach with proper hardware. List screw type.

Pro Edge

- Position end panel to rest on carriage feet. (Dwg. 10.1)
- Using the special TEK screws provided (**packet marked in Box #1**), attach end panels by screwing *through upright post of shelving into the end panel*. Secure end panel at three points along each side of panel

Designer Edge

- Position end panel to rest on carriage feet. (Dwg. 10.1)
- Drill 3 (ea.), 1/8" “pilot holes” (per side) from the outside of the end panel through the shelving upright..
- Using the wood screws provided, attach end panels by screwing *through upright post of shelving into the end panel*. Secure end panels at all six points

Steel

- Position end panel to rest on carriage feet. (Dwg. 10.1)
- Using the 1" self-taping TEK screws provided, attach end panels by screwing *through upright post of shelving into the end panel*. Secure end panels at all six points

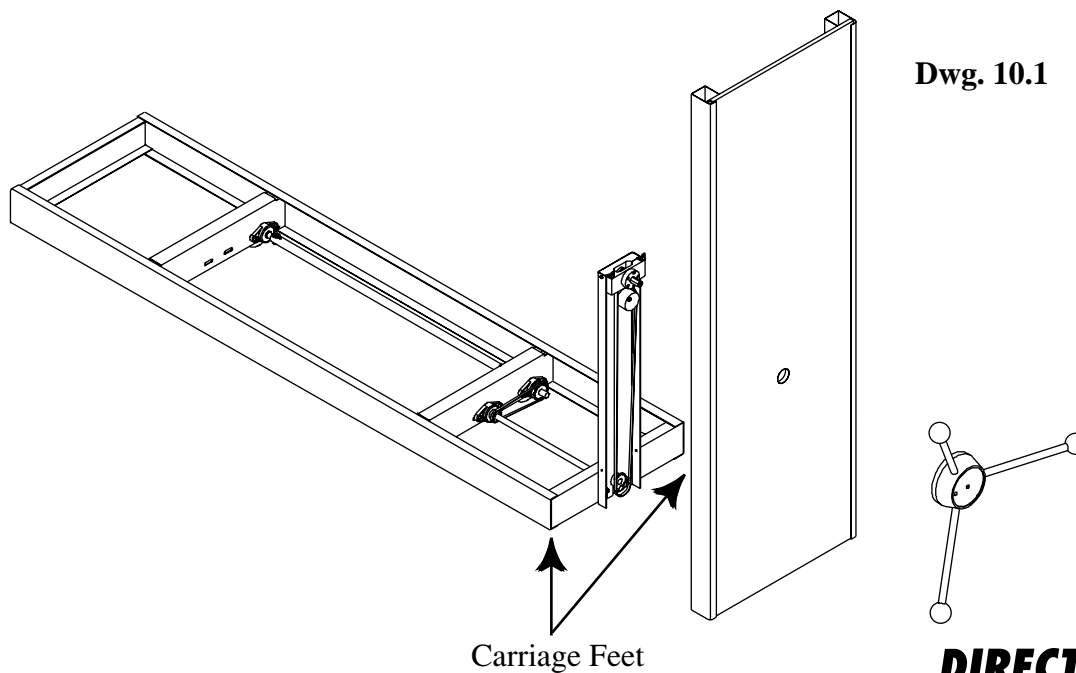

Handle and Label Assembly

- Assemble spokes onto hub. (Dwg. 11.1) Unscrew knob on lock pin and insert lock pin through hole on back of hub.
- Slide assembly over the hexagon shaft as pictured and secure with handle hub connector screw. (See page 3, Fig. 8) Attach handle hub connector screw using screw bit. (See page 3, Fig. 9)
- Apply SpacePro label.
- Secure or slide lock pin into locking position. (Dwg. 11.2)
- Now, turn handle to right and while applying pressure to spoke, re-install lock pin knob.
- Pull-out lock pin, disengaging locking mechanism.

